

Ex-Resistance Temperature Detector cable sensor RKW 9

for gas explosion hazardous areas and areas with combustible dust

In general   

The temperature sensors manufactured by Reckmann GmbH (R58®) are solely intended for the measurement of process temperatures in solid, liquid and gaseous media. This cable sensor are especially for measuring of a surface temperature on pipeline.

Application area:

Uncritical process conditions in the machine and plant engineering, power plant technology, pipeline construction, chemicals industry, beverage industry.

Depended on electrical and thermal parameters for operating with the following types of protection:

II 1G Ex ia IIC T1...T6 Ga oder
II 1D Ex ia IIIC T135 °C Da.

For installation please see our operating instructions

Stock-number-code: RKW-9.

Technical datas

- **Measuring insert** (fig. 1/2-4) cable and sensor are directly connected, isolated and mounted in the sensor tube
- **Sensor** depending on use
thin film or ceramic according to IEC / EN 60751
in 1 x 2-, 1 x 3-, 1 x 4-, 2 x 2-, 2 x 3- or 2 x 4 wire circuit.
Recommended operating temperature on the measuring tip
- 40°C up to + 180°C.
Accuracy class according to IEC / EN 60751.
Notice: process- and operating temperature are the same and depended on cable and plug connector. Sensors with \varnothing 3 mm and more than 4 inner conductors, \varnothing < 3 mm, \varnothing > 3 mm and more than 6 inner conductors are considered to be non-insulated or grounded in accordance with IEC / EN 60079-11 (dielectric strength) and must be connected to equipotential bonding of the system throughout the intrinsically safe circuit for safety reasons, taking into account the special conditions according to IEC / EN 60079-14.
- **Sensor sleeve with antikink spring** (fig.1/3-4)
Preference - \varnothing 3, 4 or 6 mm,
Standard material 1.4571.
- **Temperature range** of the cable (fig.1/2) fixed installed:
PVC isolated up to 80 °C, silicone isolated up to 180 °C, FEP isolated up to 205 °C,
PFA with VA shield up to 250°C, PTFE isolated up to 260 °C, GlS with VA shield up to 350 °C.
- **Temperature range** of the plug connector(fig.1/1):
Compensation plug connector(Typ B) -40 °C bis 200 °C, Lemo -40 °C bis 200 °C and -40 °C M12 / M8 up to 85 °C.
- **Stainless steel clamp** (fig. 1/5) diameter approx. 10 mm to approx. 400 mm.

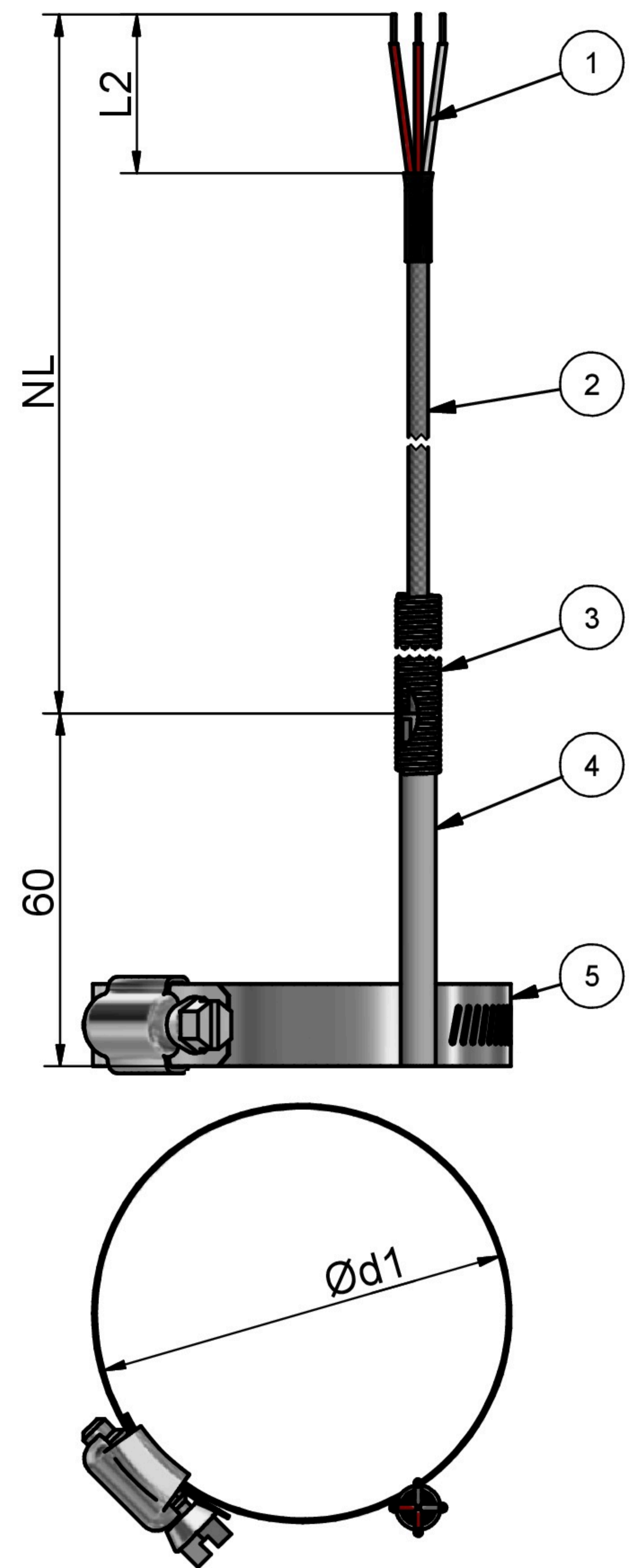
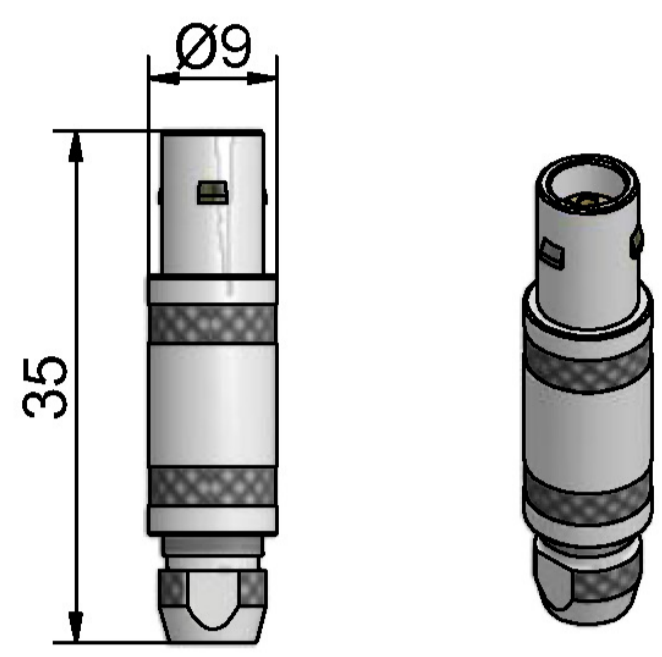

fig. 1

Optional plug connector

Examples of plug connectors with connection scheme



Lemo plug size 0

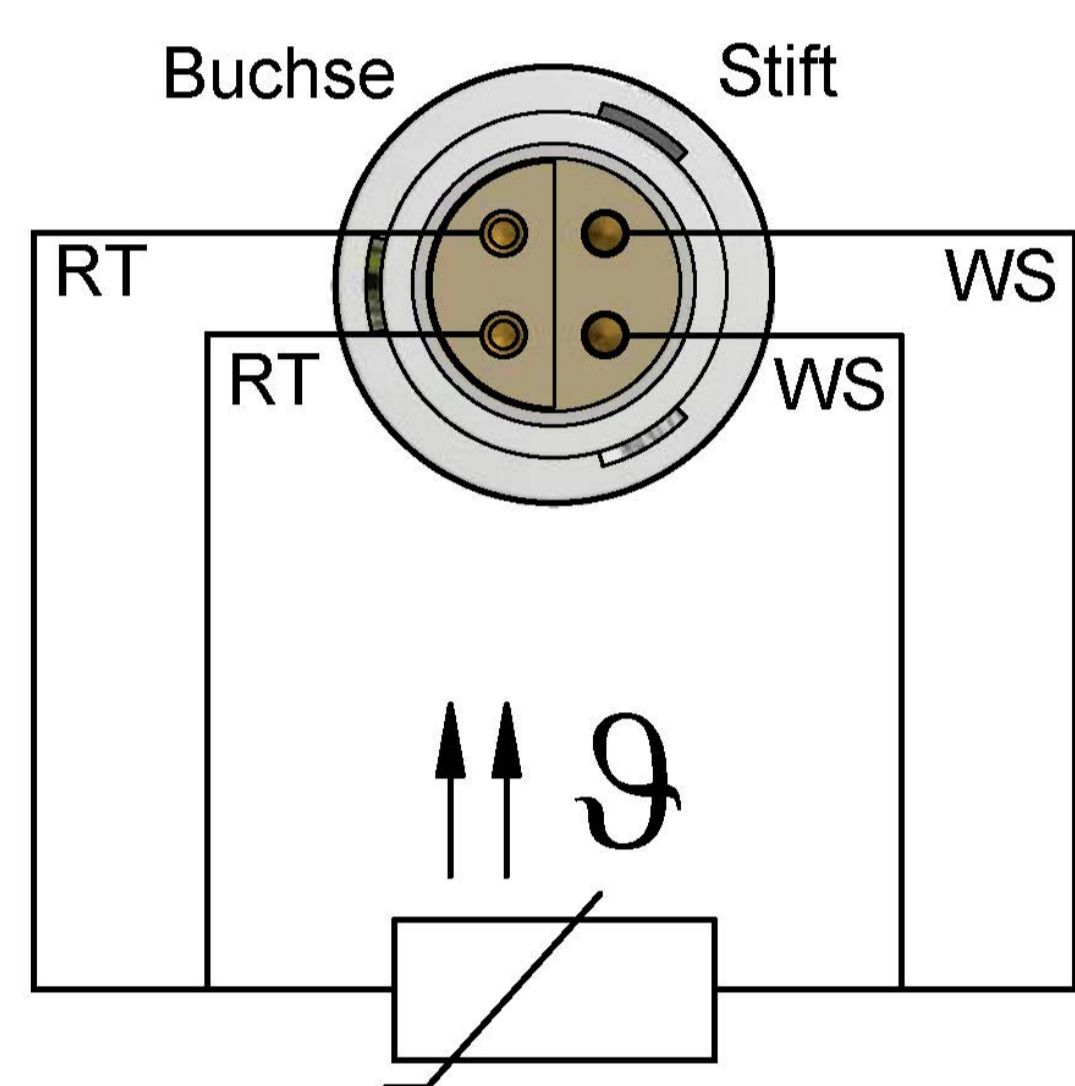

Lemo plug 1 x 4 wire front view

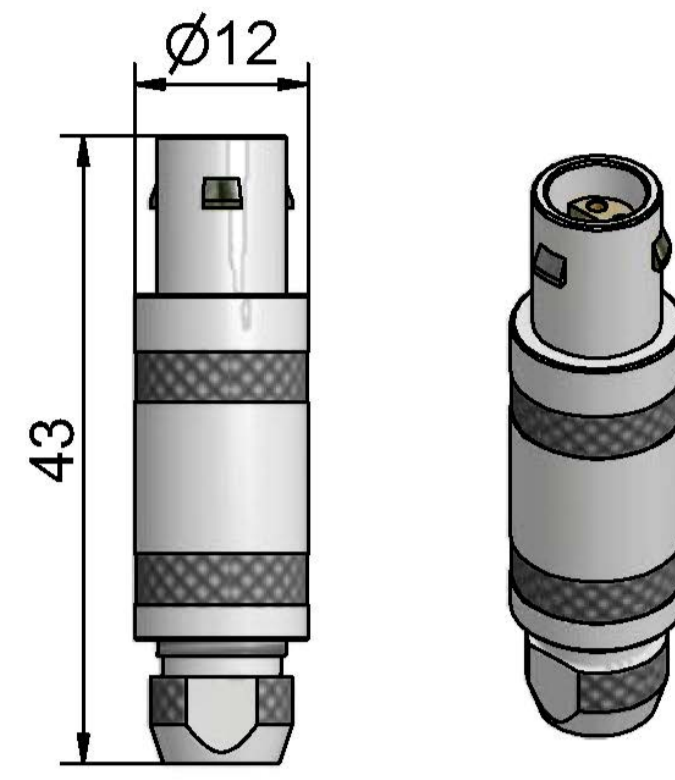

Lemo plug size 1

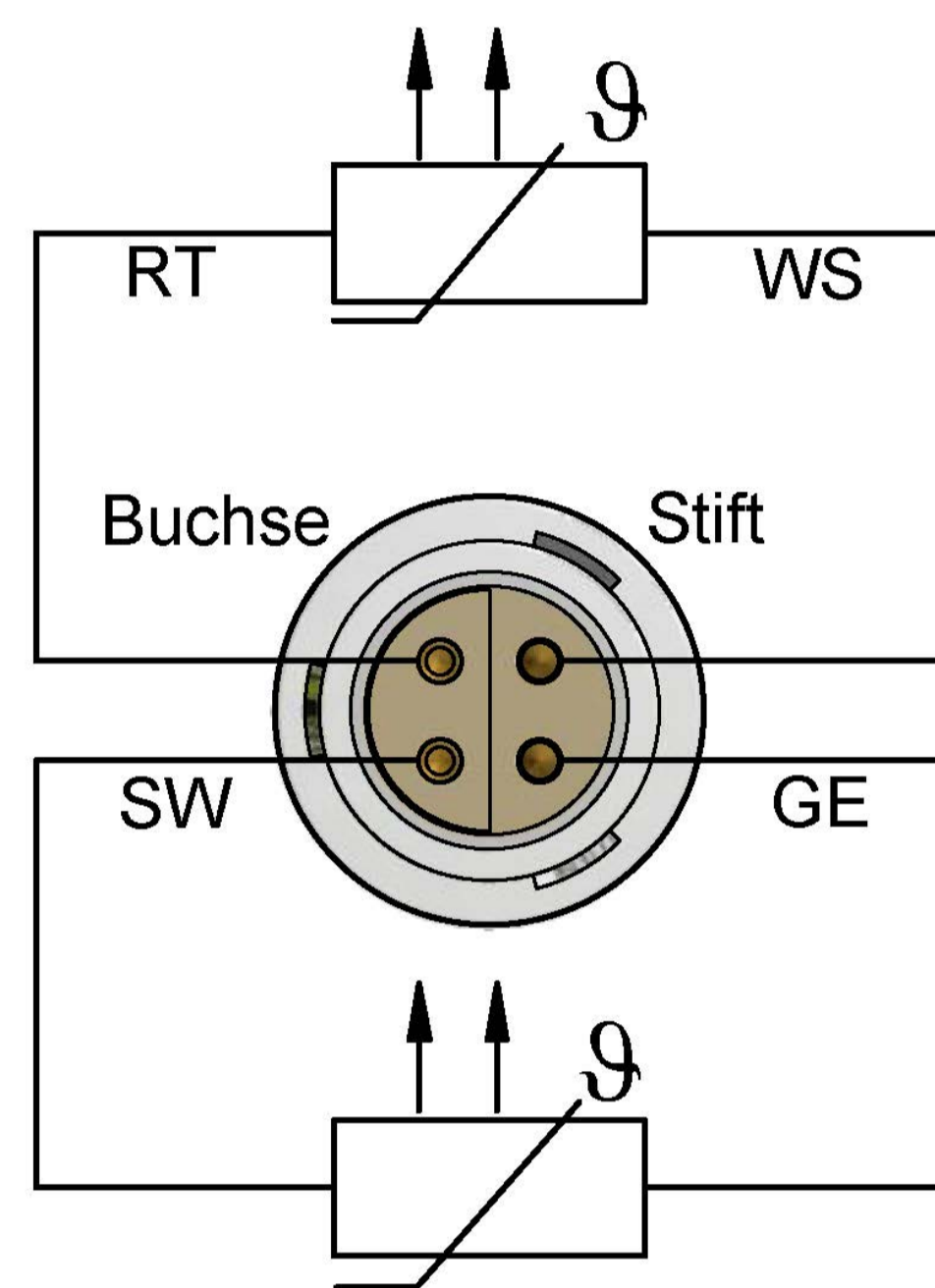

Lemo plug 2 x 2 wire front view

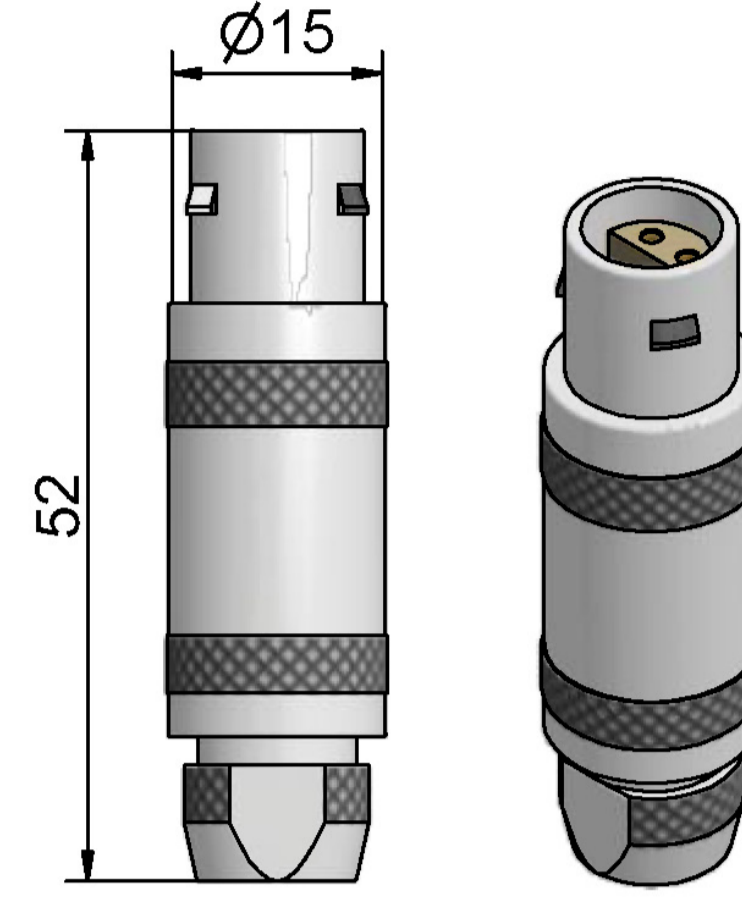

Lemo plug size 2

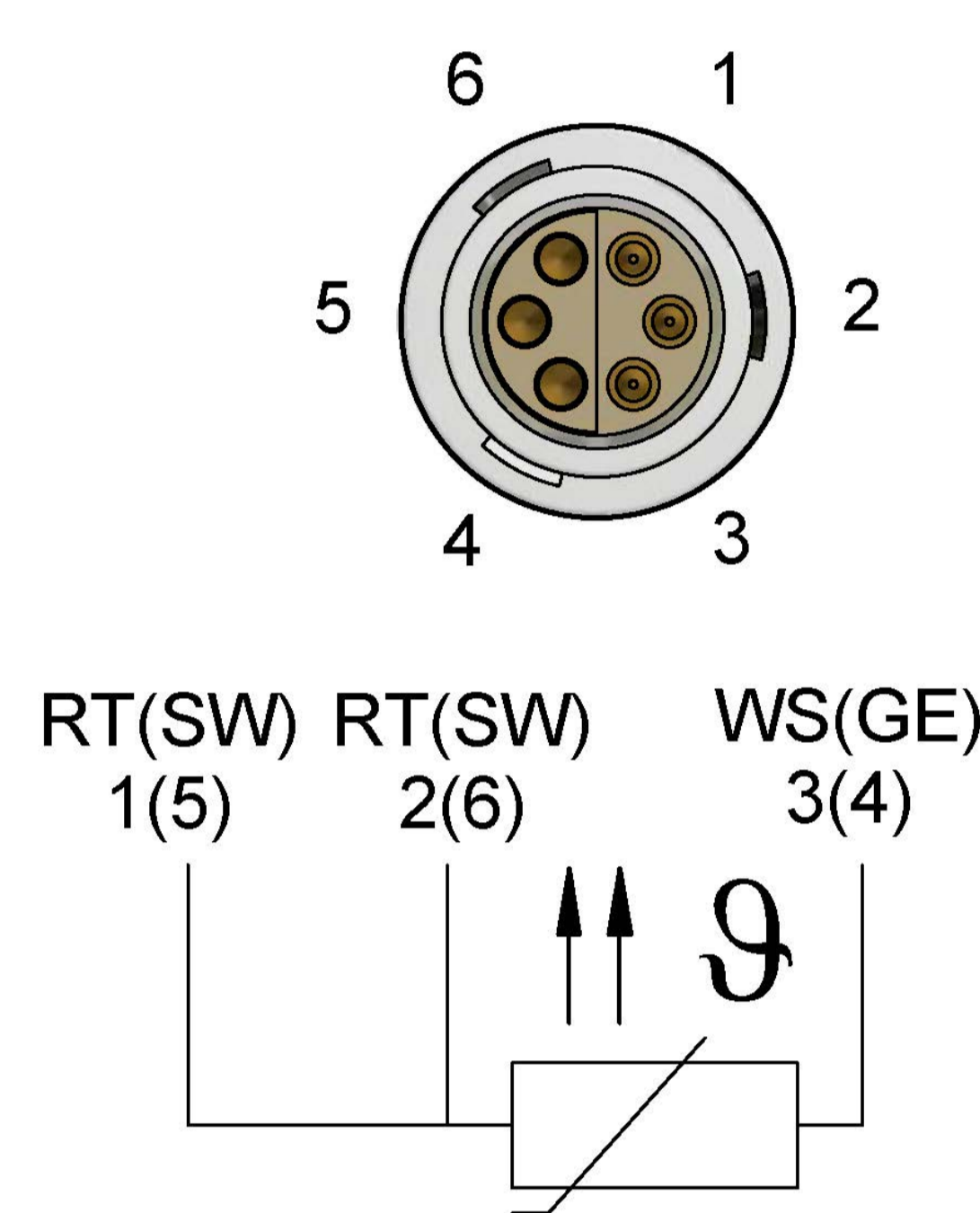

Lemo plug 2 x 3 wire front view

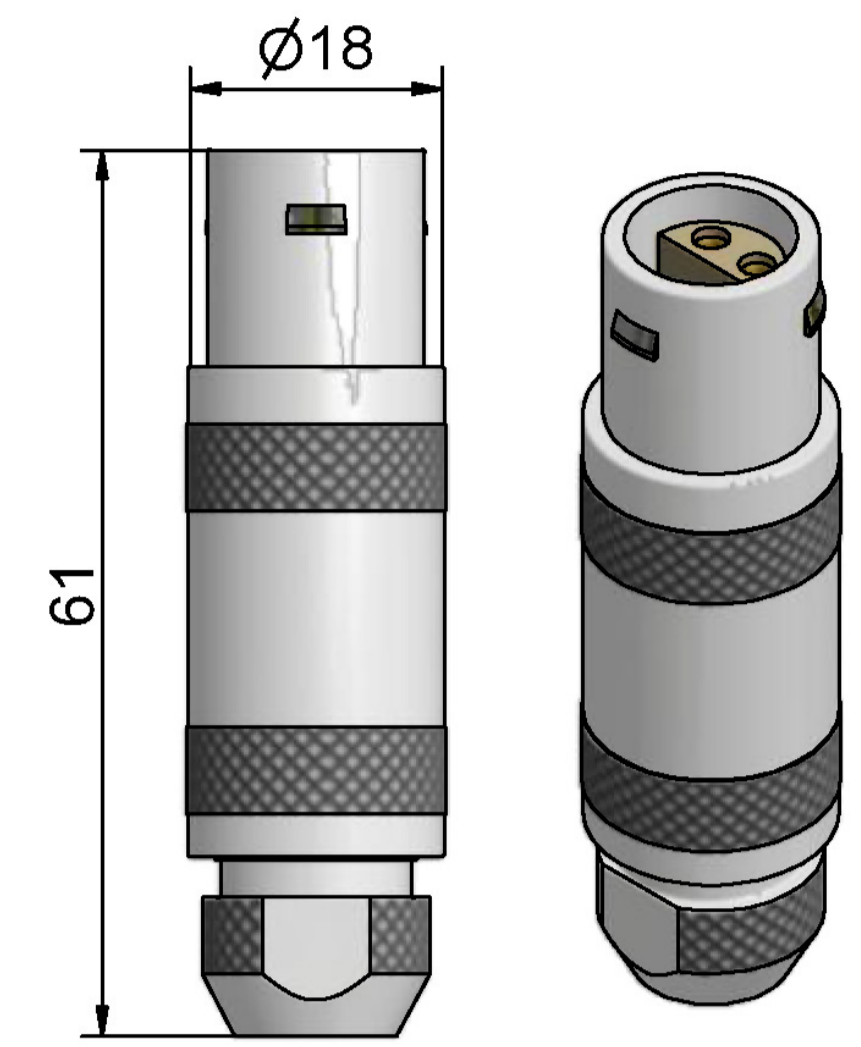

Lemo plug size 3

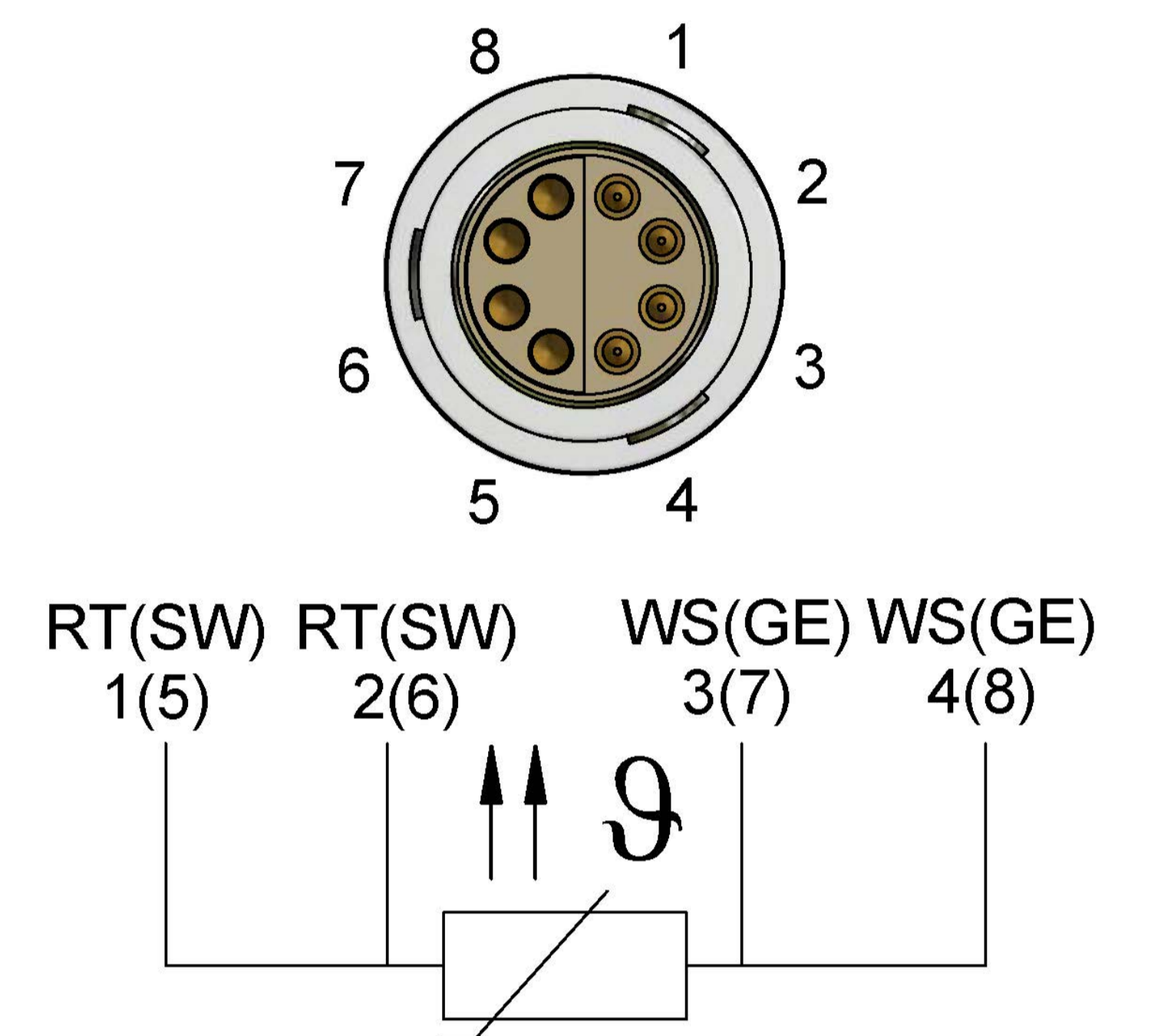

Lemo plug 2 x 4 wire front view

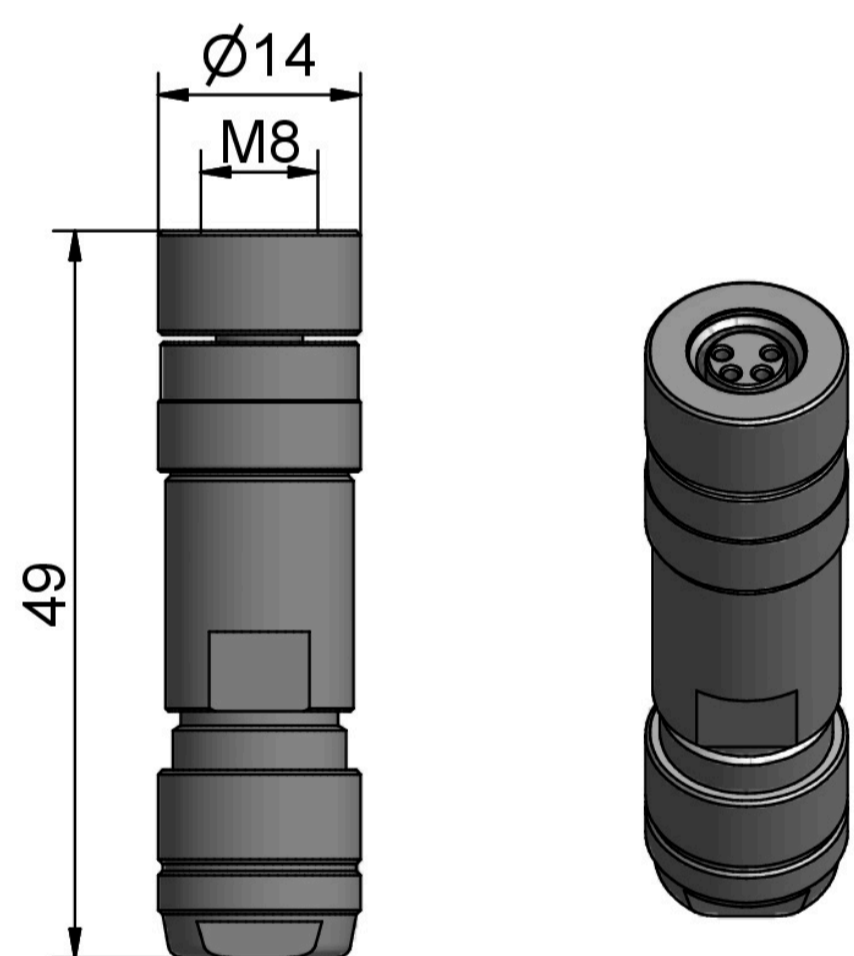

M8 socket 4 - terminal screened

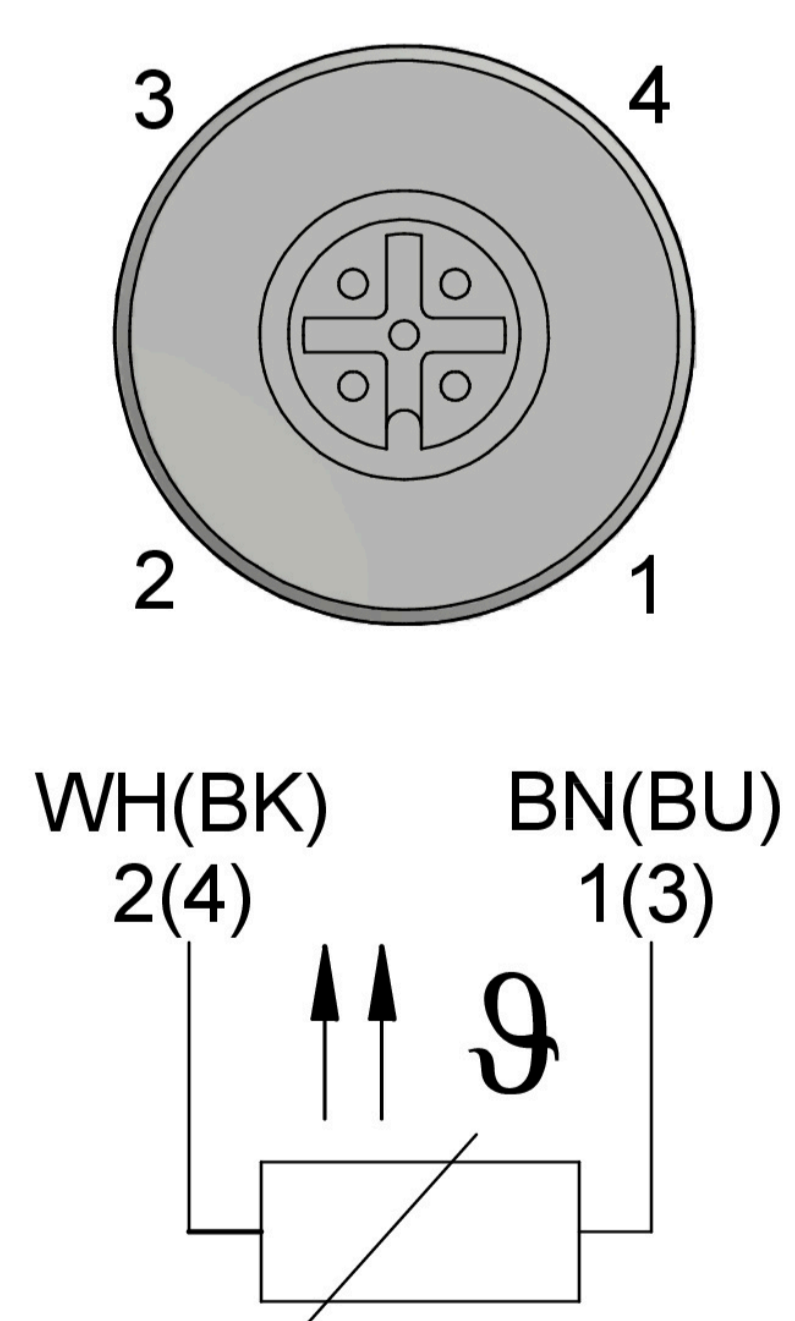

M12 socket 2 x 2 wire front view A - code

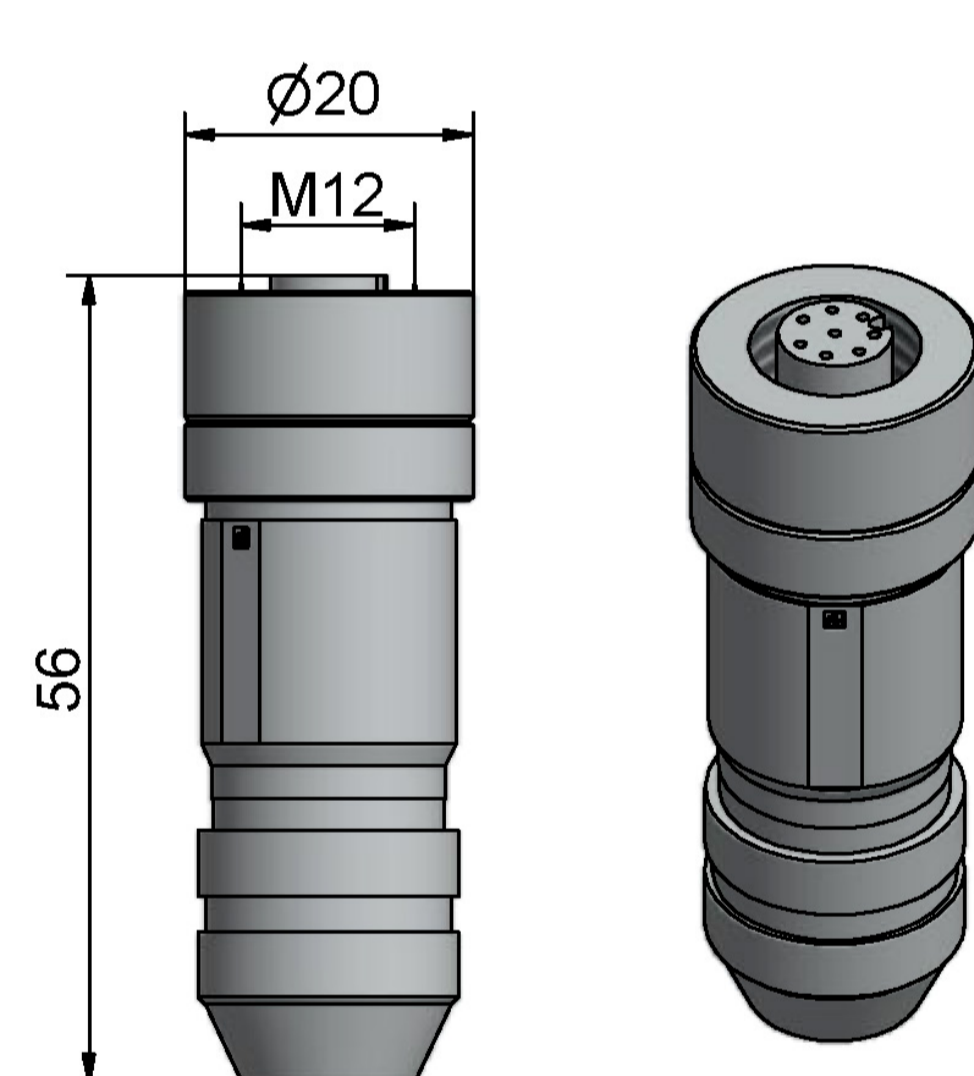

M12 socket 8 terminal screened

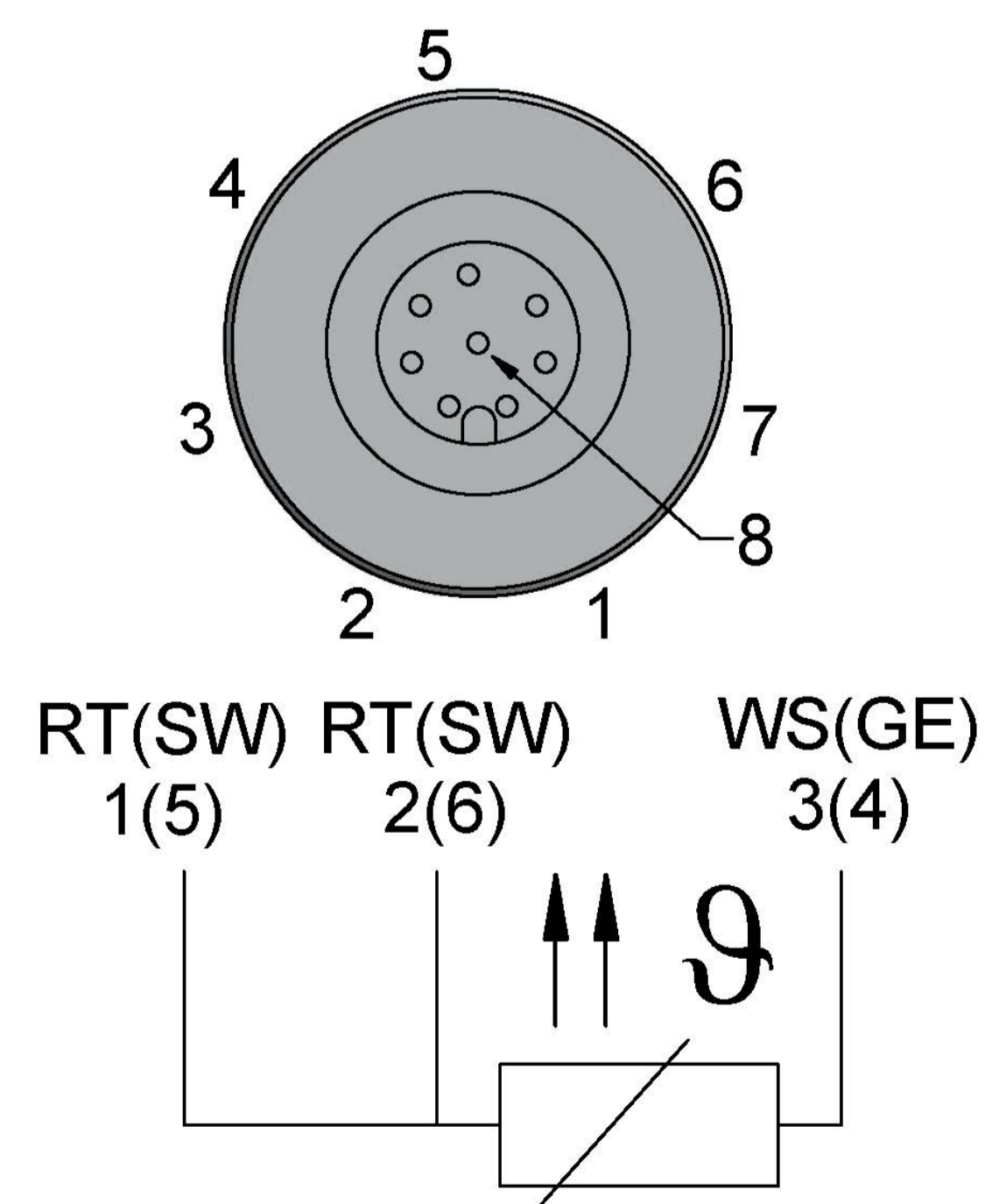

M12 socket 2 x 3 wire front view A - code

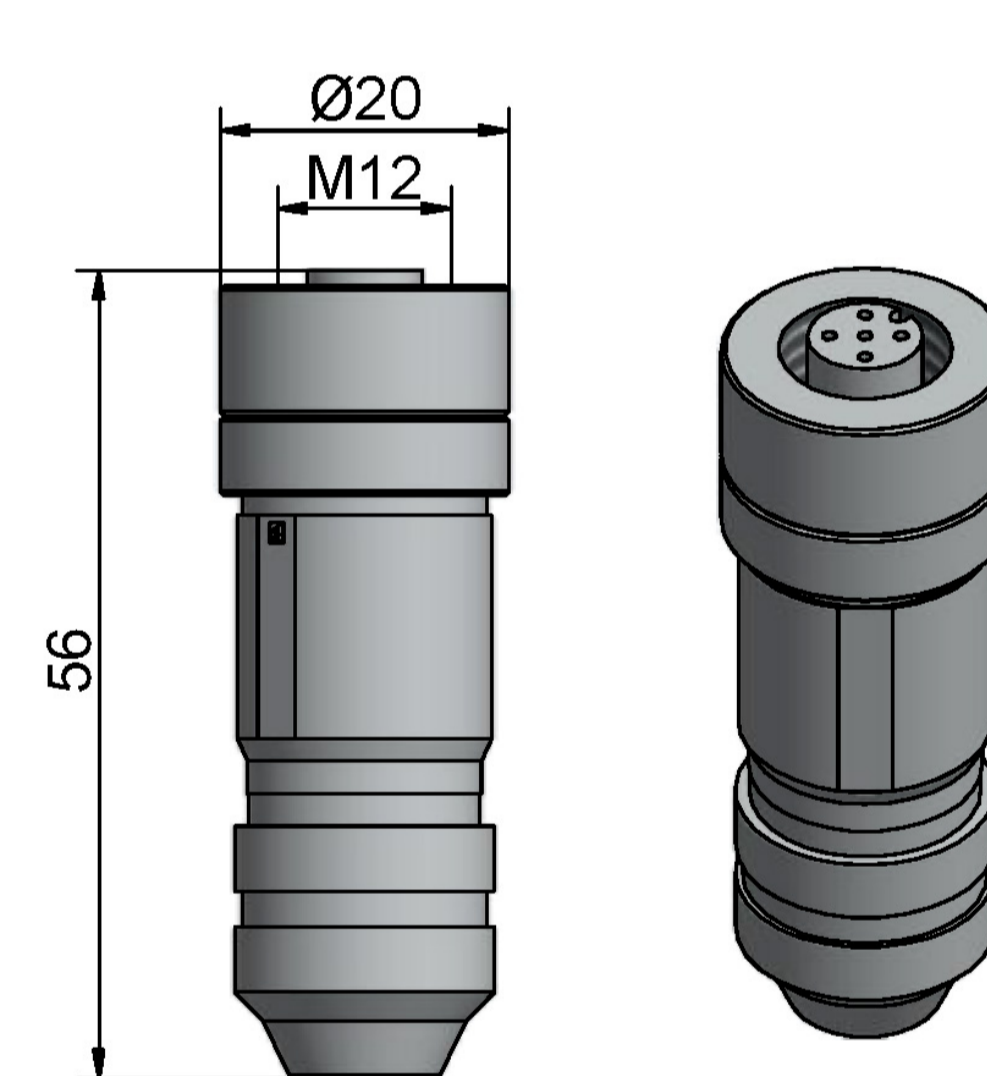

M12 socket 4 terminal screened

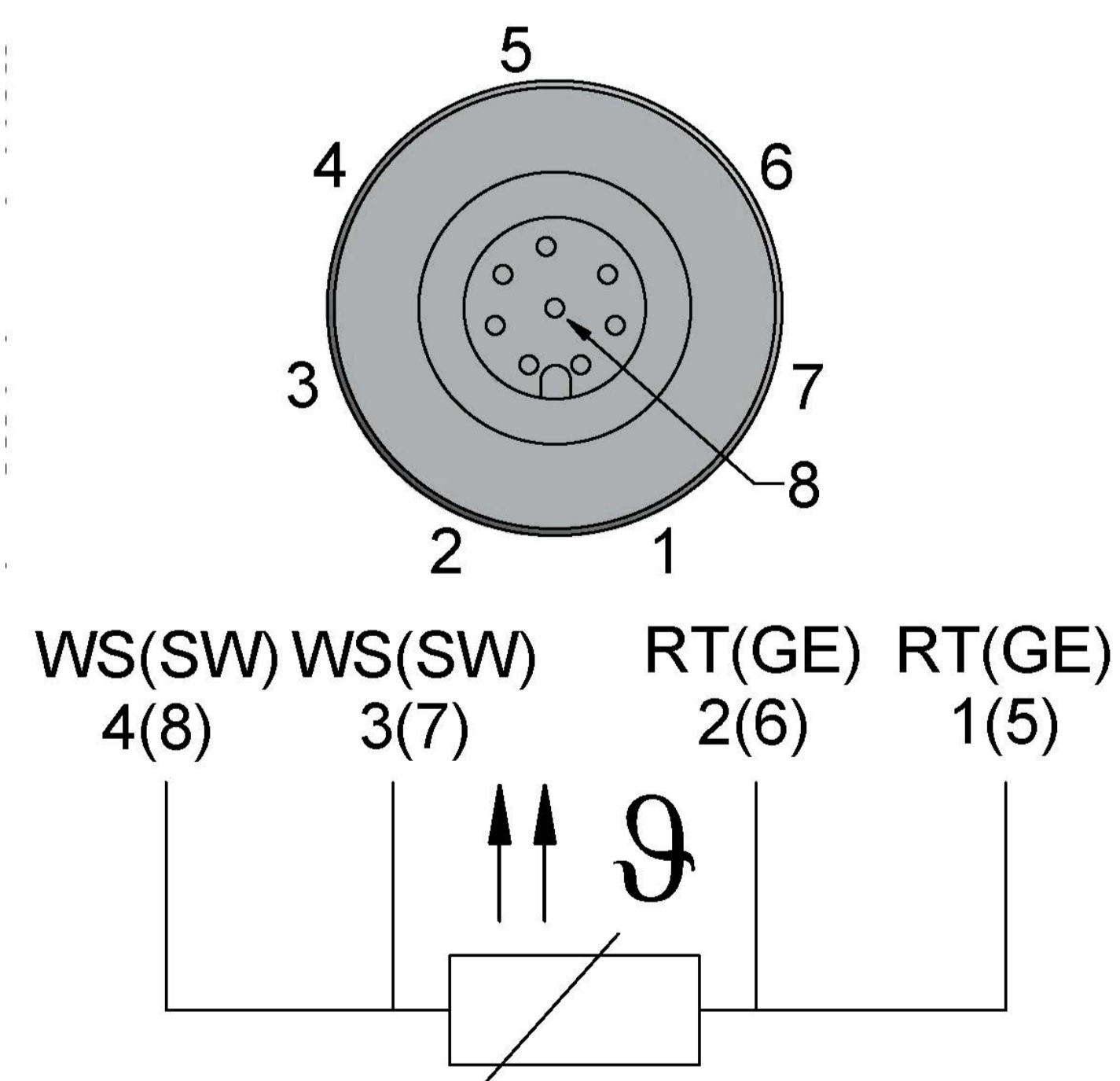

M12 socket 2 x 4 wire front view A - code

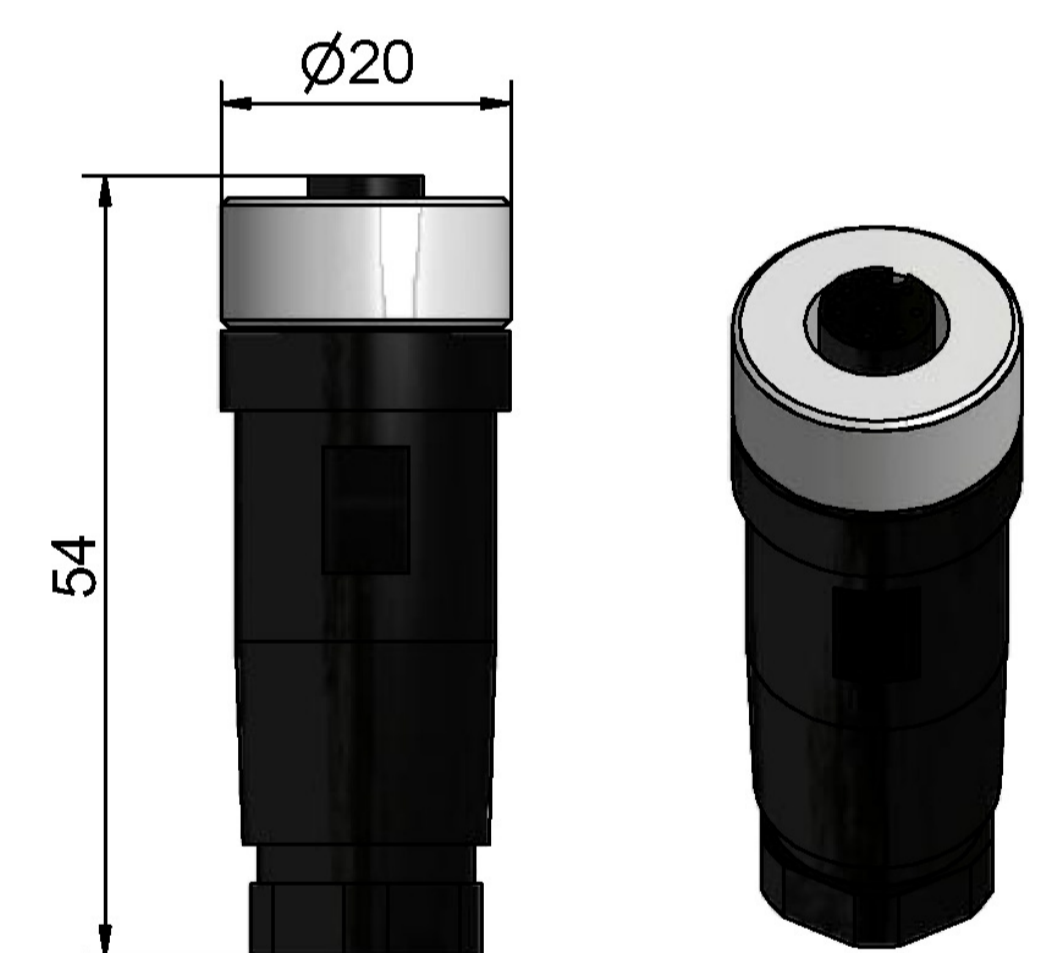

M12 socket 8 terminal

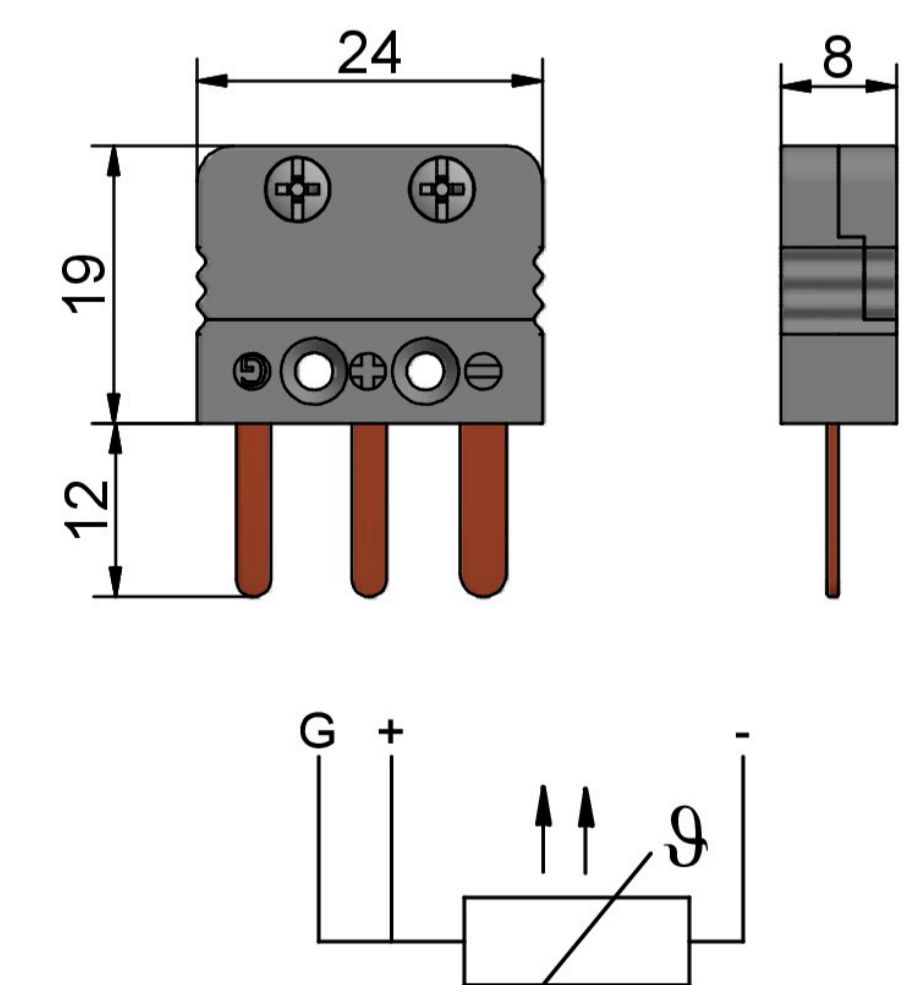

Mini plug type B (copper contacts)